

ENERGIZER 346

SILVER OXIDE

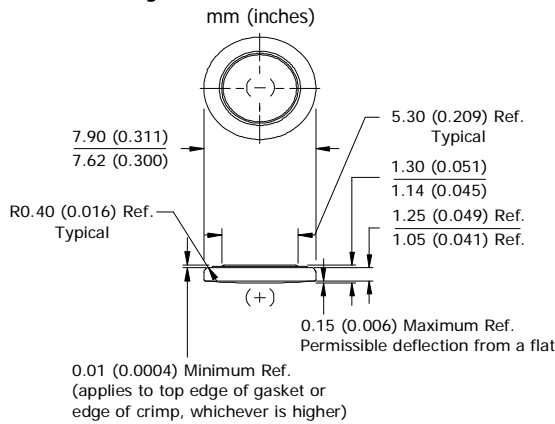

Industry Standard Dimensions



Specifications

- Chemical System:** Silver Oxide (Zn/Ag₂O)
- Nominal Voltage:** 1.55 Volts
- Typical Capacity:** 9.5 mAh* (to 1.2 volts)
- Capacity Test:** 100K ohm continuous drain at 21°C
- Typical Weight:** 0.24 grams
- Typical Volume:** 0.06 cubic centimeters
- Impedance (40 Hz):** 30 to 40 ohms

* Varies according to the applied load, temperature, and cutoff voltage.

Cross Section

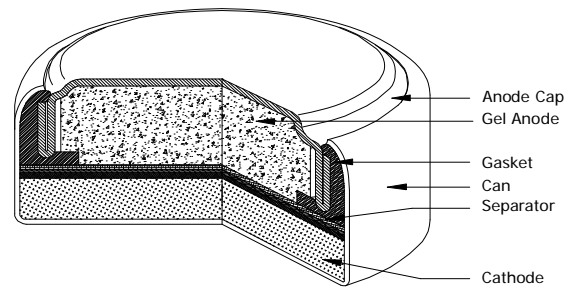

DESIGNED FOR USE ON CONTINUOUS LOW DRAIN

Typical Discharge Characteristics

Typical Performance at 21°C (70°F)

Schedule: Continuous
Typical Drain @ 1.55V: 0.016 milliamperes
Load: 100K ohm

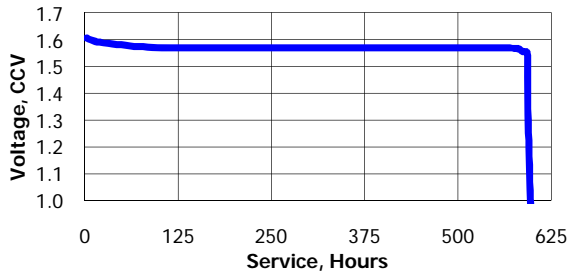

<u>Schedule</u>	<u>Typical Drains</u> at 1.55V (milliamperes)	<u>Load</u> (ohm)	<u>Cutoff</u> 1.2V (hours)
Continuous	0.016	100K	594

Temperature Characteristics

Typical Performance at Low Discharge Rates

Service Effects

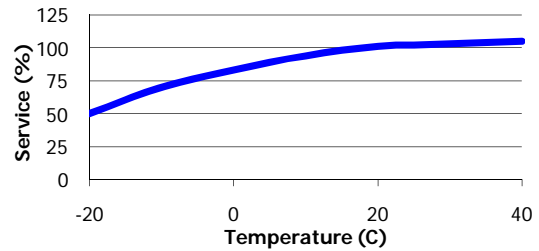

Storage Effects

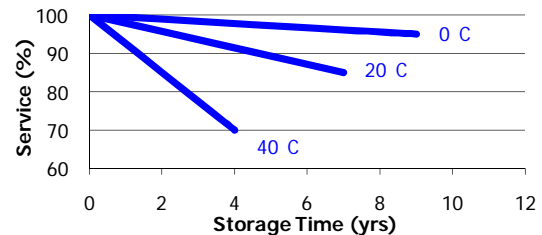

Important Notice

This datasheet contains typical information specific to products manufactured at the time of its publication.
©Energizer Holdings, Inc. - Contents herein do not constitute a warranty.