

# High Tech (LR14)

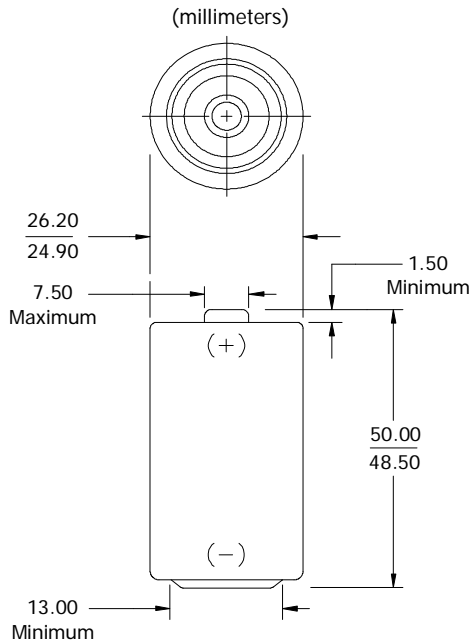

## Industry Standard Dimensions



## Specifications

<b>Classification:</b>	Alkaline
<b>Chemical System:</b>	Zinc-Manganese Dioxide (Zn/MnO <sub>2</sub> ) No added mercury or cadmium
<b>Designation:</b>	IEC-LR14
<b>Nominal Voltage:</b>	1.5 volts
<b>Nominal IR:</b>	150 to 300 milliohms (fresh)*
<b>Operating Temp:</b>	-18°C to 55°C
<b>Typical Weight:</b>	66.0 grams
<b>Typical Volume:</b>	27.0 cubic centimeters
<b>Jacket:</b>	Plastic Label
<b>Shelf Life:</b>	7 years at 21°C (80% of initial capacity)
<b>Terminal:</b>	Flat Contact

\* For additional information, please reference the [IR technical white paper](#).

## Milliamp-Hours Capacity

Continuous discharge to 0.8 volts at 21°C

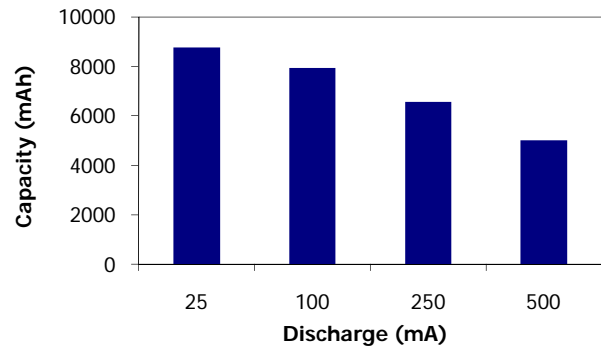

## Industry Standard Testing (21°C):

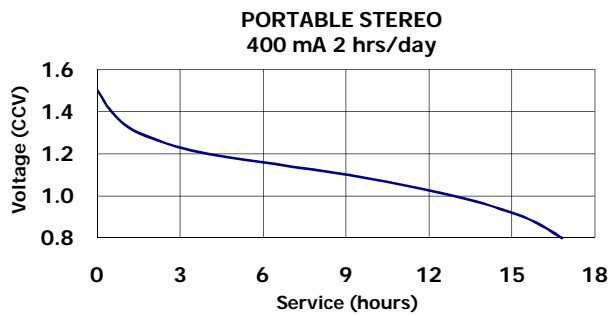

## Battery Selection Indicator

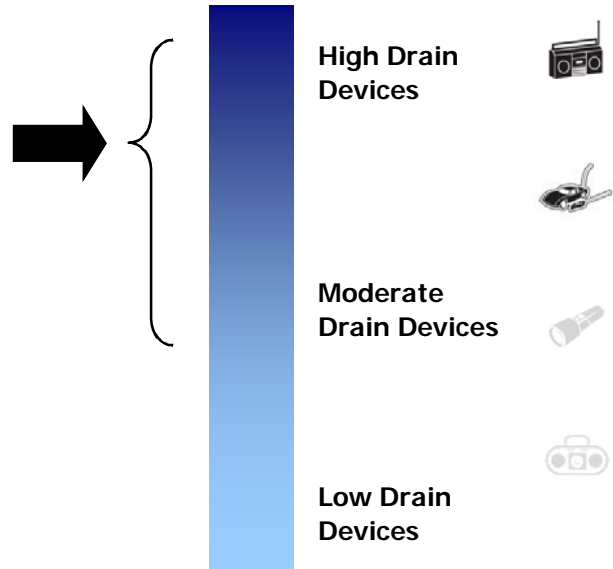

## Important Notice

This data sheet contains typical information specific to products manufactured at the time of its publication.  
©Energizer Holdings, Inc. - Contents herein do not constitute a warranty.