



Eveready Battery Company, Inc.

Checkerboard Square
St. Louis, MO 63164
Telephone 1-800-383-7323
Internet: www.energizer.com

Engineering Data

ENERGIZER NO. 313

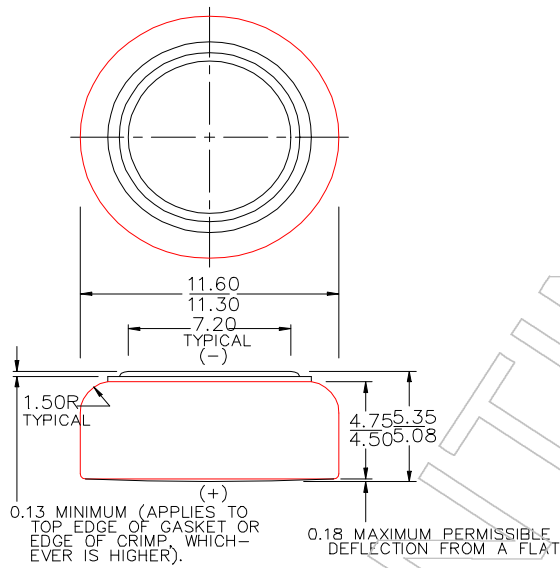

Chemical System: Mercuric Oxide (Zn/HgO)
Designation: ANSI / NEDA-1152M, IEC-MR44
Average Service Capacity (to 1.2 volts): 245 mAh
(Rated Capacity at 6,500 ohms @ 21°C)
Typical Weight: 2.6 grams (0.09 oz.)
Terminals: Flat Contact
Volume: 0.5 cubic centimeters (0.03 cubic in.)

Dimensions (mm)

Millimeters	Inches
0.13	0.005
0.18	0.007
1.50	0.059
4.50	0.177
4.75	0.187
5.08	0.200
5.35	0.211
7.20	0.283
11.30	0.445
11.60	0.457

IMPORTANT NOTICE

This data sheet contains information specific to batteries manufactured at time of its publication. Please contact your Energizer representative for most current information. Contents herein do not constitute a warranty.