

**ENERGIZER 315Z**

**ZEROMERCURY**

**SILVER OXIDE**



**Industry Standard Dimensions**

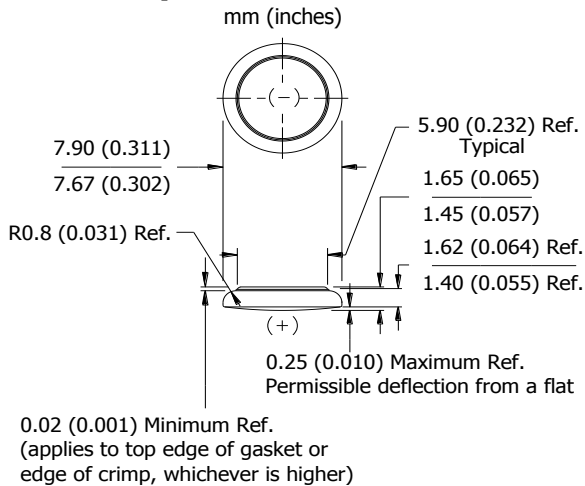

DESIGNED FOR USE ON CONTINUOUS LOW DRAIN

**Specifications**

<b>Chemical System:</b>	Silver Oxide (Zn/Ag <sub>2</sub> O)
<b>Nominal Voltage:</b>	1.55 Volts
<b>Typical Capacity:</b>	23 mAh* (to 1.2 volts)
<b>Capacity Test:</b>	30K ohm continuous drain at 21°C
<b>Typical Weight:</b>	0.33 grams (0.012 oz.)
<b>Typical Volume:</b>	0.08 cubic centimeters (0.005 cubic inch)
<b>Impedance (40 Hz):</b>	45 to 55 ohms

\* Varies according to the applied load, temperature, and cutoff voltage.

**Cross Section**

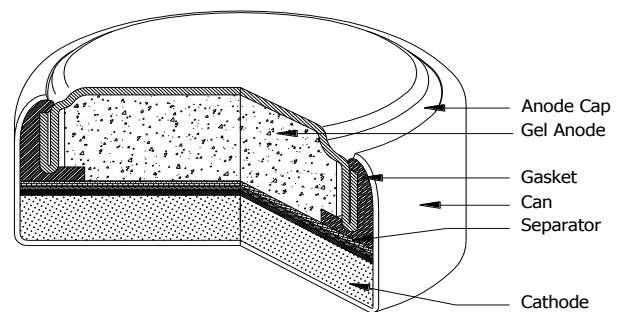

**Typical Discharge Characteristics**

Typical Performance at 21°C (70°F)

**Schedule:** Continuous  
**Typical Drain @1.55V:**  
0.052 milliamperes  
**Load:** 30K ohm

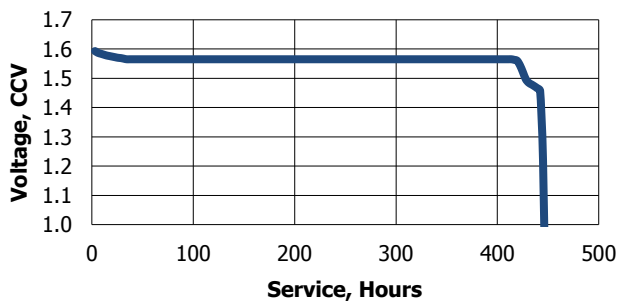

<u>Schedule</u>	<u>Typical Drains</u> at 1.55V (milliamperes)	<u>Load</u> (ohm)	<u>Cutoff</u> (hours)
Continuous	0.052	30K	445

**Temperature Characteristics**

Typical Performance at Low Discharge Rates

**Service Effects**

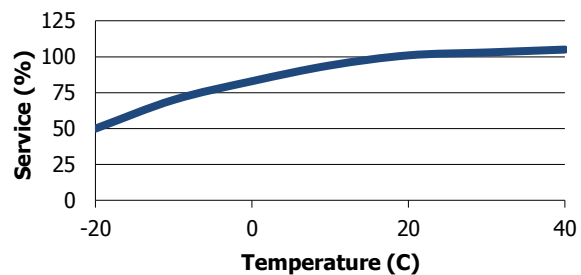

**Storage Effects**

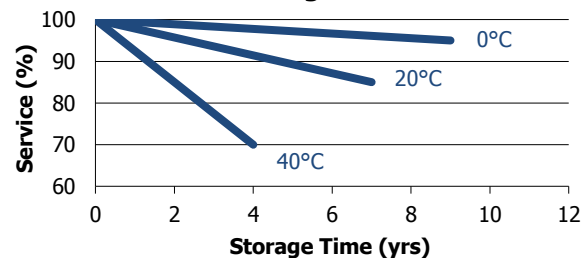

**Important Notice**

This datasheet contains typical information specific to products manufactured at the time of its publication.  
©Energizer Holdings, Inc. - Contents herein do not constitute a warranty.