

ENERGIZER 335

ZEROMERCURY

SILVER OXIDE



Industry Standard Dimensions

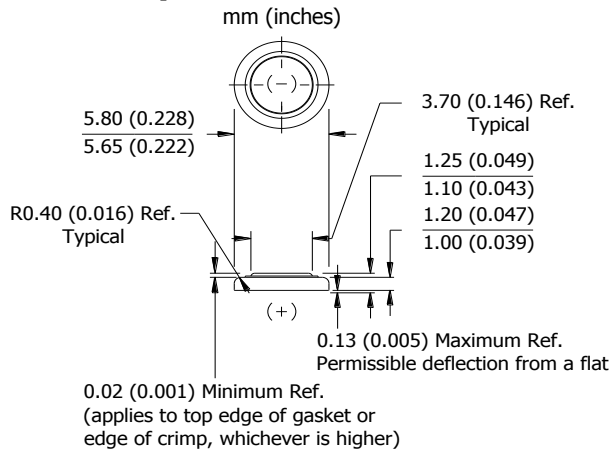

Specifications

- Chemical System:** Silver Oxide (Zn/Ag₂O)
- Nominal Voltage:** 1.55 Volts
- Typical Capacity:** 6 mAh* (to 1.2 volts)
- Capacity Test:** 150K ohm continuous drain at 21°C
- Typical Weight:** 0.13 grams (0.004 oz.)
- Typical Volume:** 0.03 cubic centimeters (0.001 cubic inch)
- Impedance (40 Hz):** 50 to 60 ohms

* Varies according to the applied load, temperature, and cutoff voltage.

Cross Section

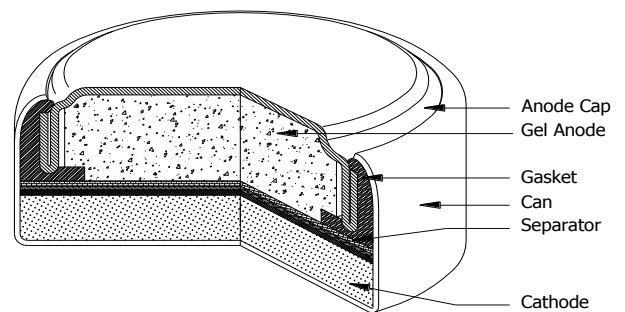

DESIGNED FOR USE ON CONTINUOUS LOW DRAIN

Typical Discharge Characteristics

Typical Performance at 21°C (70°F)

Schedule: Continuous
Typical Drain @1.55V:
0.01 milliamperes
Load: 150K ohm

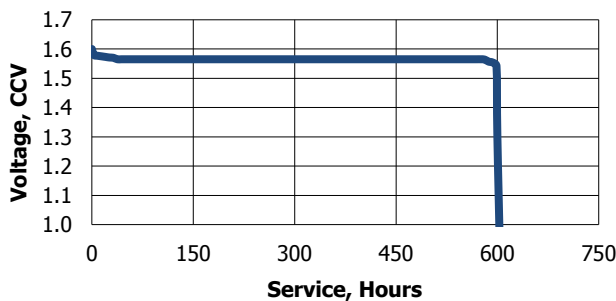

Schedule	Typical Drains at 1.55V (milliamperes)	Load (ohm)	Cutoff (hours)
Continuous	0.01	150K	600

Temperature Characteristics

Typical Performance at Low Discharge Rates

Service Effects

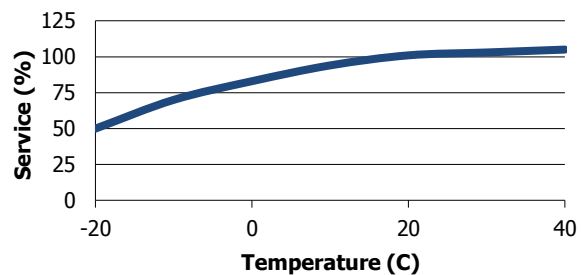

Storage Effects

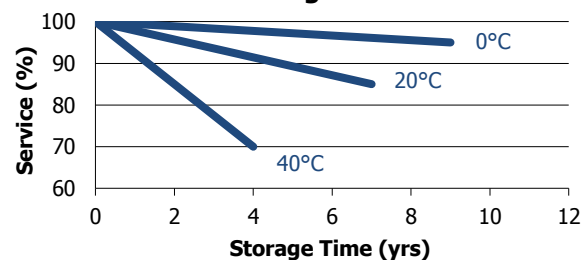

Important Notice

This datasheet contains typical information specific to products manufactured at the time of its publication.
©Energizer Holdings, Inc. - Contents herein do not constitute a warranty.