

ENERGIZER A91

AA

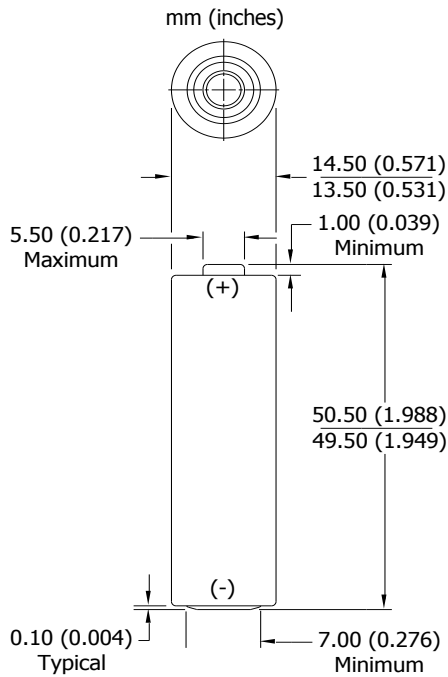

Industry Standard Dimensions



Classification:	Alkaline
Chemical System:	Zinc-Manganese Dioxide (Zn/MnO ₂) No added mercury or cadmium
Designation:	ANSI-15A, IEC-LR6
Nominal Voltage:	1.5 volts
Operating Temp:	-18°C to 55°C (0°F to 130°F)
Typical Weight:	23.0 grams (0.8 oz.)
Typical Volume:	8.1 cubic centimeters (0.5 cubic inch)
Jacket:	Plastic Label
Shelf Life:	10 years at 21°C
Terminal:	Flat Contact

Performance Comparison

A91 vs. Typical Carbon Zinc (AA) at 21°C

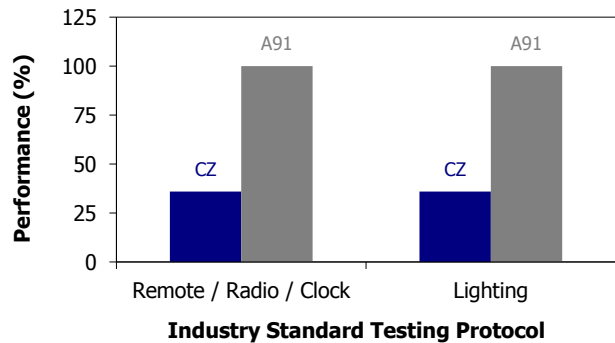

Device Selection Guide:

- Digital Camera
- Photoflash
- Games, CD's, MD's
- Tape Player
- Lighting
- Toy
- Remote Control
- Radio
- Clock

Battery Selection Indicator

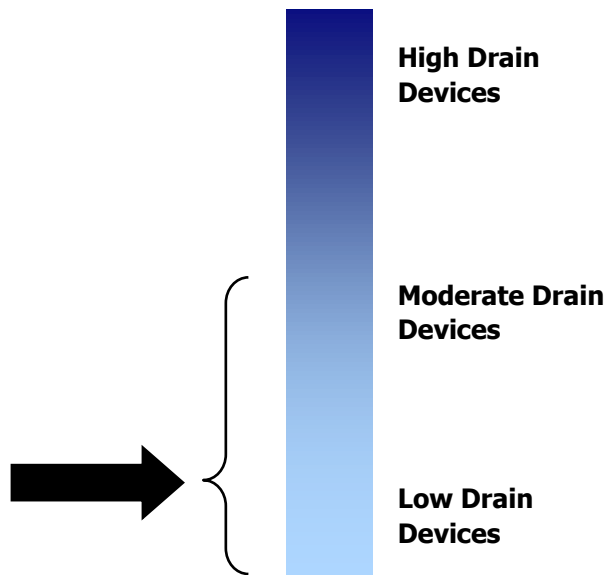

Important Notice

This data sheet contains typical information specific to products manufactured at the time of its publication.
©Energizer Holdings, Inc. - Contents herein do not constitute a warranty.