

**ENERGIZER A93**

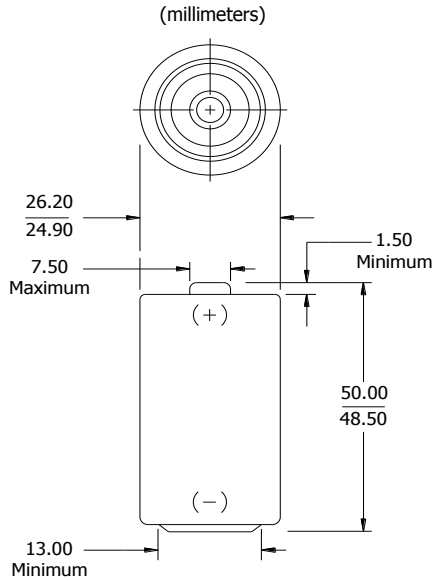

**Industry Standard Dimensions**



**Specifications**

<b>Classification:</b>	Alkaline
<b>Chemical System:</b>	Zinc-Manganese Dioxide (Zn/MnO <sub>2</sub> ) No added mercury or cadmium
<b>Designation:</b>	IEC-LR14
<b>Nominal Voltage:</b>	1.5 volts
<b>Operating Temp:</b>	-18°C to 55°C
<b>Typical Weight:</b>	66.0 grams
<b>Typical Volume:</b>	27.0 cubic centimeters
<b>Jacket:</b>	Plastic Label
<b>Shelf Life:</b>	7 years at 21°C
<b>Terminal:</b>	Flat Contact

**Performance Comparison**

A93 vs. Typical Carbon Zinc (C) at 21°C

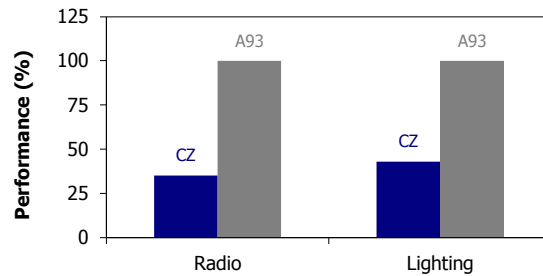

Industry Standard Testing Protocol

**Device Selection Guide:**

Portable Stereo



Toy



Lighting



Radio



**Battery Selection Indicator**

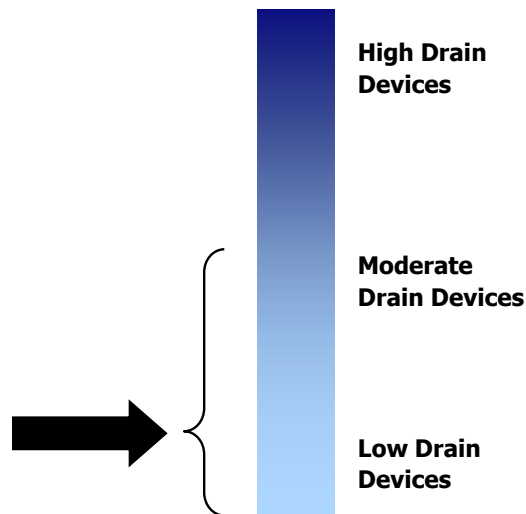

**Important Notice**

This datasheet contains typical information specific to products manufactured at the time of its publication.  
©Energizer Holdings, Inc. - Contents herein do not constitute a warranty.