

ENERGIZER E675HH

Specially designed for use in humid climatic conditions.



(top view) (bottom view)

Industry Standard Dimensions

(millimeters)

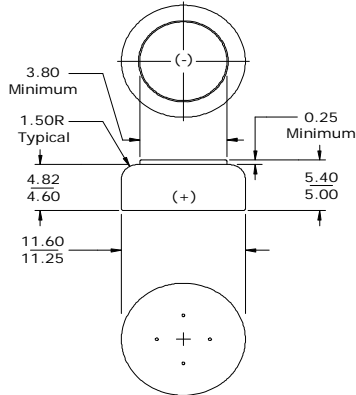

Typical Discharge Characteristics

Schedule: 16 hours/day
Typical Drain @ 1.3V:
2.1 & 1.3 milliamperes
Load: 625 & 1,000 ohms

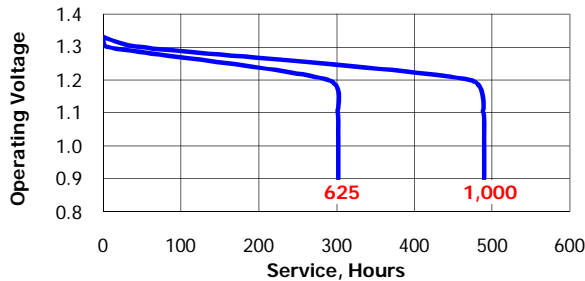

Simulated Application Test

Typical Performance at 21°C & 50% RH

Schedule:	Typical Drains: at 1.3V (milliamperes)	Load (ohms)	Cutoff 0.9V (hours)
16 Hours/Day	2.1	625	302
16 Hours/Day	1.3	1,000	488

Specifications

Chemical System:	Zinc Air (ZnO ₂)
Tab Color:	Blue
Designation:	IEC-PR44
Nominal Voltage:	1.4 Volts
Typical Capacity:	635 mAh (to 0.9 volts) (Rated at 326 ohms at 21°C/65% RH)
Typical Weight:	1.9 grams
Typical Volume:	0.5 cubic centimeters

Zinc Air

Impedance

The total opposition that a battery offers to the flow of alternating current. Impedance is a combination of resistance and reactance.

The typical impedance of these cells on open circuit and during useful discharge varies from 5-20 ohms. This applies over a frequency range of 40-5,000 hertz at the current drains shown below.

Impedance vs. Frequency

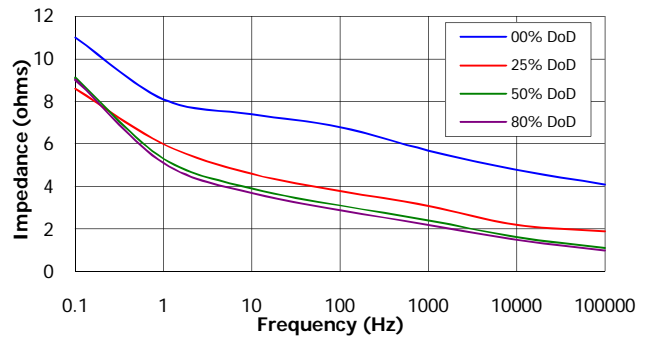

Impedance vs. Depth of Discharge

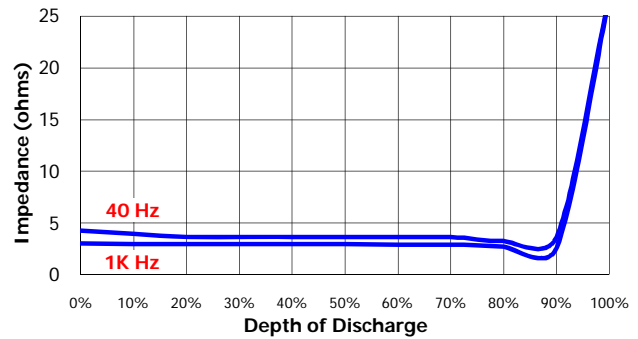

Important Notice

This datasheet contains typical information specific to products manufactured at the time of its publication.
©Energizer Holdings, Inc. - Contents herein do not constitute a warranty.