

Rate Capability

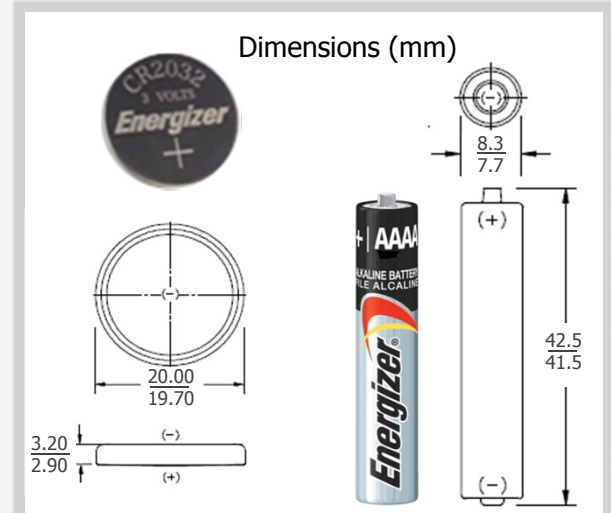

CR2032 / AAAA Alkaline

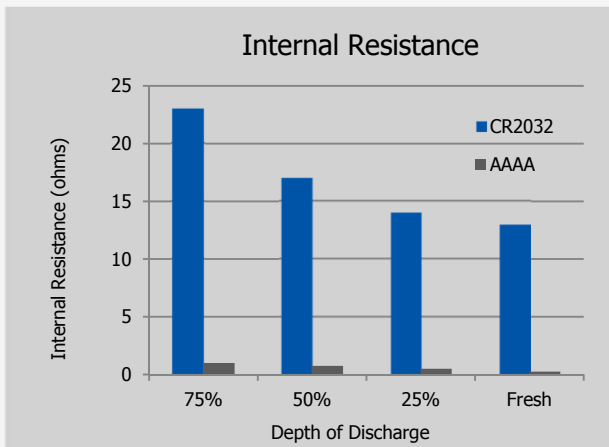

Internal Resistance

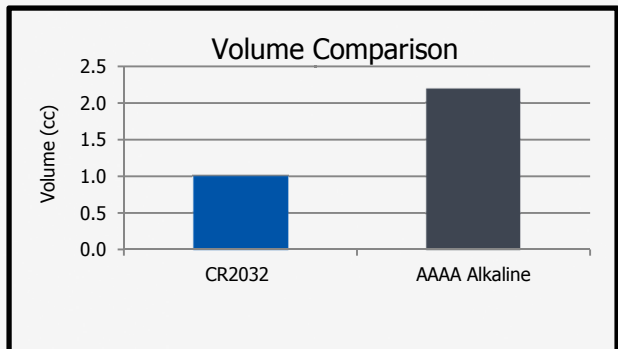

Advantages of Alkaline AAAA vs. CR2032

- Higher capacity
- Works at higher continuous drain rates
- Better peak power capability
- Similar OEM cost
- Eliminates disposal concerns – lithium coin contains perchlorates
- Eliminates safety concern regarding swallowing lithium coin

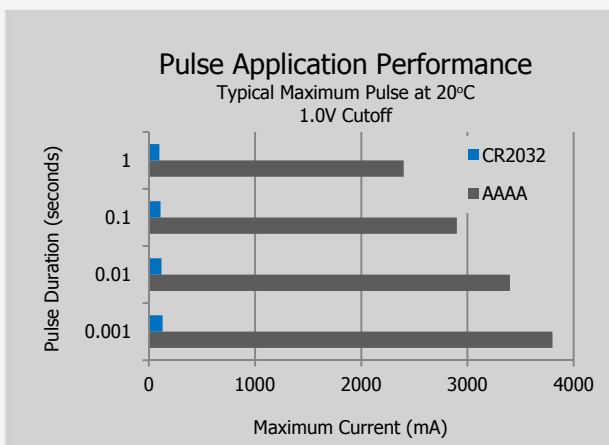

Pulse Capability