

ENERGIZER 522

9V

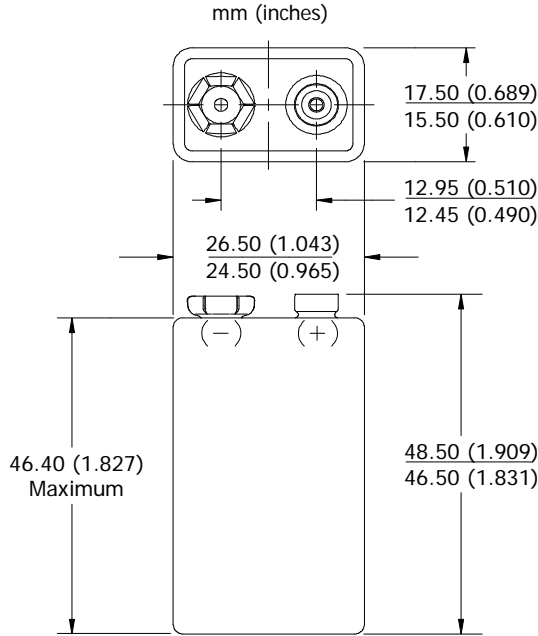

Industry Standard Dimensions



Specifications

Classification:	Alkaline
Chemical System:	Zinc-Manganese Dioxide (Zn/MnO ₂) No added mercury or cadmium
Designation:	ANSI 1640A, IEC-6LF22
Nominal Voltage:	9.0 volts
Operating Temp:	-18°C to 55°C
Typical Weight:	46.0 grams
Typical Volume:	21.0 cubic centimeters
Jacket:	Metal
Shelf Life:	5 years at 21°C
Terminal:	Miniature Snap

Milliamp-Hours Capacity

Continuous discharge to 4.8 volts at 21°C

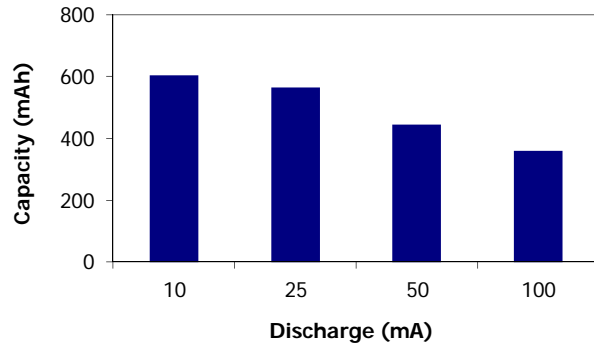

Industry Standard Tests (21°C)

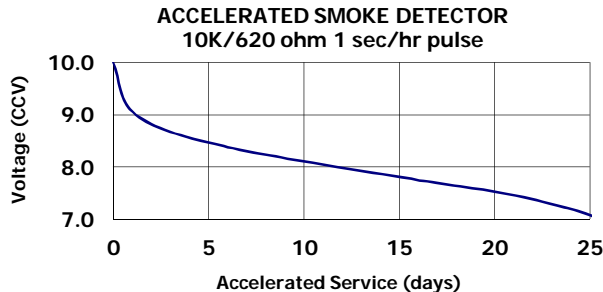
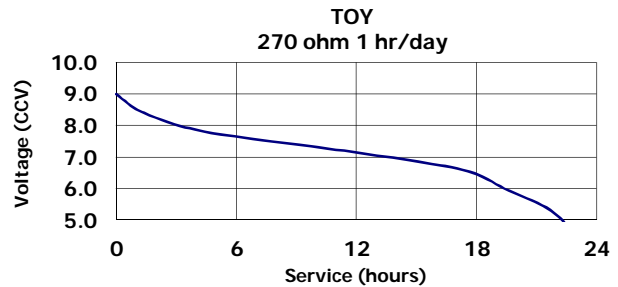
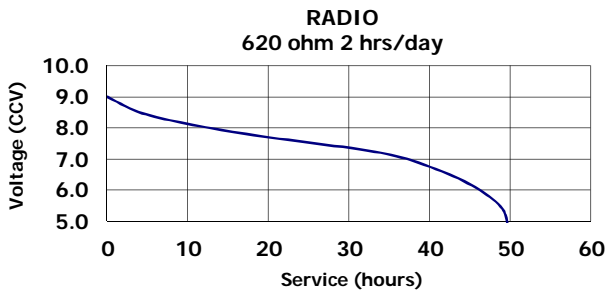

Important Notice

This datasheet contains typical information specific to products manufactured at the time of its publication.
©Energizer Holdings, Inc. - Contents herein do not constitute a warranty.