

ENERGIZER 675 size - **Mercury Free**

ZnAir

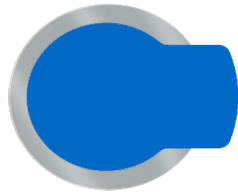

General Information

Chemical System: Zinc Air (Zn/O₂)
Tab Color: Blue
Designation: ANSI-7003ZD, IEC-PR44
Nominal Voltage: 1.45 Volts
Typical Weight: 1.8 grams (0.06 oz.)
Typical Volume: 0.6 cubic centimeters (0.04 cubic inch)

Industry Standard Dimensions

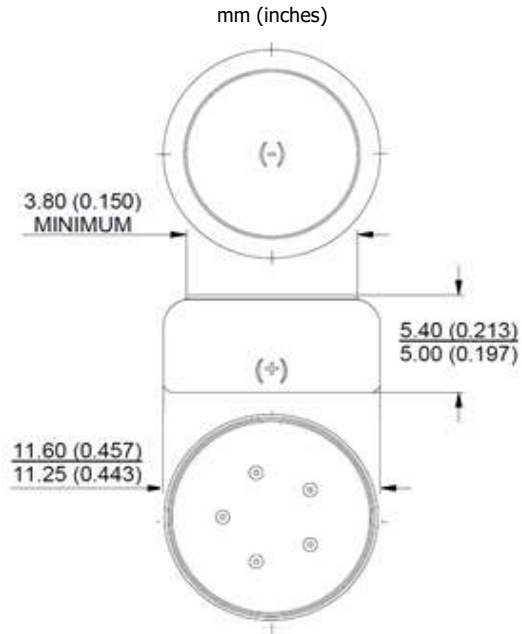

Typical Discharge Characteristics

ANSI/IEC Industry Standards / Standard Test Protocol
 (15/5 mA .1S/1H59M 59.9S 12H at 21C)

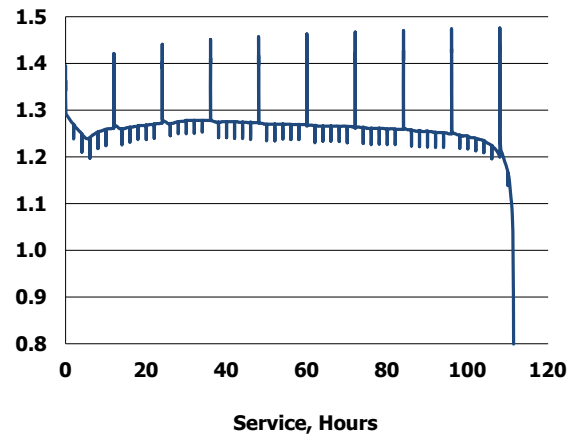

Typical Discharge Characteristics

ANSI/IEC Industry Standards / High Drain Test Protocol
 (24/8 mA .1S/1H59M 59.9S 12H at 21C)

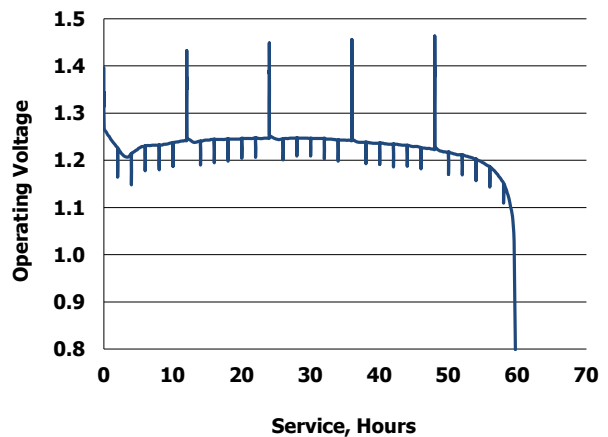

Important Notice

This datasheet contains typical information specific to products manufactured at the time of its publication.
Contents herein do not constitute a warranty and are for reference only.